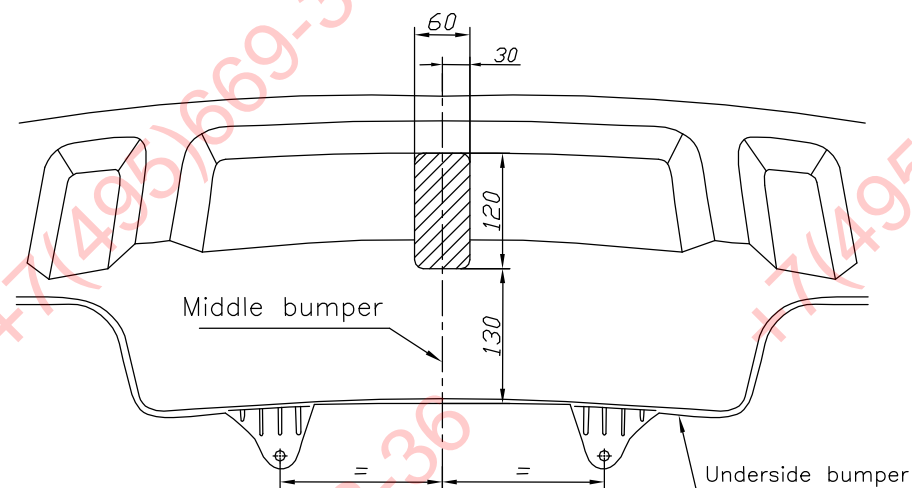

Figure 2. Bumper's cut



ФАРКОП.РФ

+7 (495) 669-38-36

Towing hitch accessories:

Pos. 1 Main bar PCS.: 1	Pos. 5 Bolt 8,8 B M12x75mm PCS.: 1	Pos. 10 Plain washer ø30xø10,5x2,5mm PCS.: 8
	Pos. 6 Bolt 8,8 B M12x70mm PCS.: 1	Pos. 11 Spring washer ø12,2mm PCS.: 6
Pos. 2 Tow ball PCS.: 1	Pos. 7 Bolt 8,8 B M12x40mm PCS.: 4	Pos. 12 Spring washer ø10,2mm PCS.: 8
Pos. 3 Socket plate PCS.: 1	Pos. 8 Bolt 8,8 B M10x100mm PCS.: 6	Pos. 13 Nut 8 B M12 PCS.: 4
Pos. 4 Side bracket PCS.: 2	Pos. 9 Plain washer ø13mm PCS.: 6	Pos. 14 Nut 8 B M10 PCS.: 2
		Pos. 15 Ball cover PCS.: 1



PPUH AUTO-HAK Sp.J.

Produkcja Zaczepów Kulowych
Henryk & Zbigniew Nejman
76-200 SŁUPSK ul. Słoneczna 16K
tel/fax (059) 8-414-414; 8-414-413
E-mail: office@autohak.com.pl
www.autohak.com.pl

Towing hitch (without electrical set)

Class: **A50-X** Cat. no. **A26**

Designed for:

Manufacturer: **AUDI**

Model: **Q5**

produced since 2008

Technical data:

D-value: 12,0 kN

maximum trailer weight: **2400 kg**

maximum vertical cup mass: **80 kg**

Approval number according to Directive 94/20/EC: **e20*94/20*1313*00**

Foreword

This towing hitch is designed according to rules of safety traffic regulations. The towing hitch is a safety component and can be install only by qualified personnel. Any alteration or conversion of the towing hitch is prohibited and would lead to cancellation of design certification. Remove insulating compound and underseal from vehicle (if present) in the area of the matting surfaces of the towing hitch. The vehicle manufacturer's specifications regarding trailer mass and max. vertical cup mass are decisive for driving whereat values for the towing hitch cannot be exceeded.

D-value formula:

$$\frac{\text{Max trailer weight [kg]} \times \text{Max vehicle weight [kg]}}{\text{Max trailer weight [kg]} + \text{Max vehicle weight [kg]}} \times \frac{9,81}{1000} = D \text{ [kN]}$$

FITTING INSTRUCTION

Clamp mark in acc. with		Cables joining
ISO	PN	
1	L	Left directional lights
2	+	Rear fog lights
3	31	Ground
4	R	Right directional lights
5	58R	Right side parking lights
6	54	Stoplights
7	58L	Left side parking lights

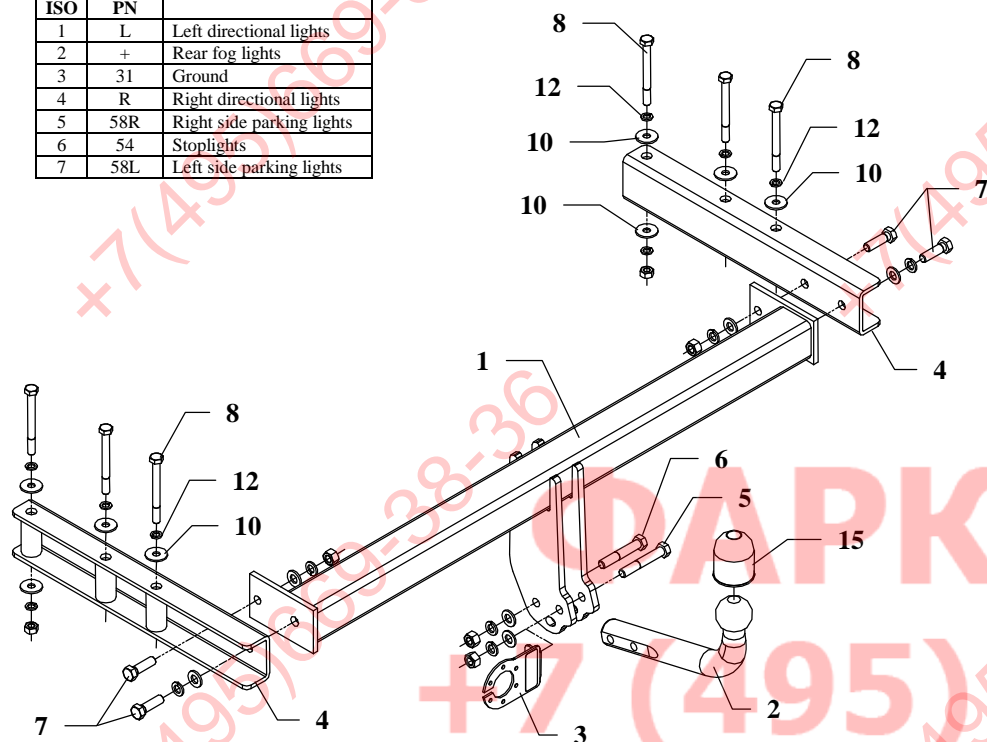

This towing hitch is designed to assembly in following cars:
AUDI Q5, produced since 2008, catalogue number **A26** and is prepared to tow trailers max total weight **2400 kg** and max vertical mass **80 kg**.

From manufacturer

Thank you for buying our product. Their reliability has been confirmed in many tests. Reliability of towing hitch depends also on correct assembly and right operation. For this reasons we kindly ask to read carefully this instruction and apply to hints.

The towing hitch should be install in points described by a car producer.

The instruction of the assembly

1. Disassemble side panels from the boot.
2. Disassemble rear bumper together with metal reinforcement (reinforcement will not used any more).
3. Disassemble last muffler's handles from left and right side of chassis.
4. Slip side brackets (pos. 4) into members in this way, so holes of brackets agree with holes prepared by car manufacturer. Fix loosely using bolts according to figure 1.
5. Between installed side brackets apply main bar of the towbar (pos. 1) and fix by bolts M12x40mm (pos. 7) as shown on the figure 1.
6. Reassemble muffler's handles.
7. Reassemble rear bumper after cut out it's fragment according to figure 2.
8. Fix tow-ball (pos. 2) with socket plate (pos. 3) using bolts M12x75mm (pos. 5) and M12x70mm (pos. 6) from accessories.
9. Tighten all bolts according to the torque shown in the table.
10. Connect electric wires of 7-poles socket according to the instruction of the car. (Recommend to make at authorized service station).
11. Complete paint layer damaged during installation.

Torque settings for nuts and bolts (8,8):

M6 - 11 Nm	M 8 - 25 Nm	M 10 - 50 Nm
M 12 - 87 Nm	M 14 - 138 Nm	M16 - 210 Nm

NOTE

After install the towing hitch you should get adequate note in registration book (at authorised service station). The car should be equipped with:

- Indicators
- Tow mirrors

After 1000km of exploitation check all bolts and nuts. The ball of towing hitch must be always kept clear and conserve with a grease.